



# ACHIEVER™ 5000

## Overhead Stirrers



### *Reliable Overhead Stirrers with Excellent Performance for Everyday Use*

OHAUS Achiever 5000™ Overhead Stirrers are designed for powerful, precise stirring, safety and simplicity in all applications. The sealed design has an IP54 rating and ensures safe mixing performance even in the most demanding applications. The keyless chuck and software controlled speed ramping provide easy set up and safe stirring to protect the sample and user. Select from five models with up to 200 Ncm torque and up to 100 L volume capacity.

#### *Unique Features:*

- Powerful mixing and constant speed is assured with the brushless motor and torque compensation technology - delivering accurate, controlled stirring of viscous liquids with quiet operation.
- Simplify set up with the Keyless Chuck - no tools required. Change shafts quickly and easily with one handed operation. This unique design will save time and effort for everyone in the lab.
- Designed for safety. The lock button prevents accidental speed changes and the motor's overload sensing technology simply shuts off stirring before an overload condition occurs to protect the sample.
- Compact and easy to use. Simple knob control combined with the bright digital display allows for precise setting and monitoring. Customize for your application with over 12 accessories.

# ACHIEVER™ 5000

Model	e-A51ST020	e-A51ST040	e-A51ST060	e-A51ST100	e-A51ST200
Stirring Speed Range	30-2000 rpm			30-1300 rpm	6-400 rpm (I) 30-2000 rpm (II)
Stirring Volume (H <sub>2</sub> O)	up to 25l		up to 40l	up to 100l	
Maximum Viscosity (cP or mPa's)	10 000	25 000	50 000	70 000	100 000
Maximum Torque (Ncm)	20	40	60	100	200
Speed Gears	1				2
Speed Accuracy	1 rpm				
Speed Control	Digital				
Display	LED				
Timer	Yes				
Lock Button	Yes				
Chuck Range (Diameter)	1 - 13 mm				
Shaft Pass Through (Diameter)	up to 8,5 mm				
Ingress Protection	IP54				
Dimensions (H x L x W)	28,5 x 23,5 x 9,0 cm				31,5 x 23,5 x 9,0 cm
Net Weight	4,1 kg				4,6 kg
Power Supply	230V, 50/60Hz				
Power Input	190W (230V)				
Working Environment	5 °C – 40 °C, 80 % RH, non-condensing				

\*RH = Relative Humidity

## Dimensional Drawings

e-A51ST020, e-A51ST040, e-A51ST060, e-A51ST100

e-A51ST200

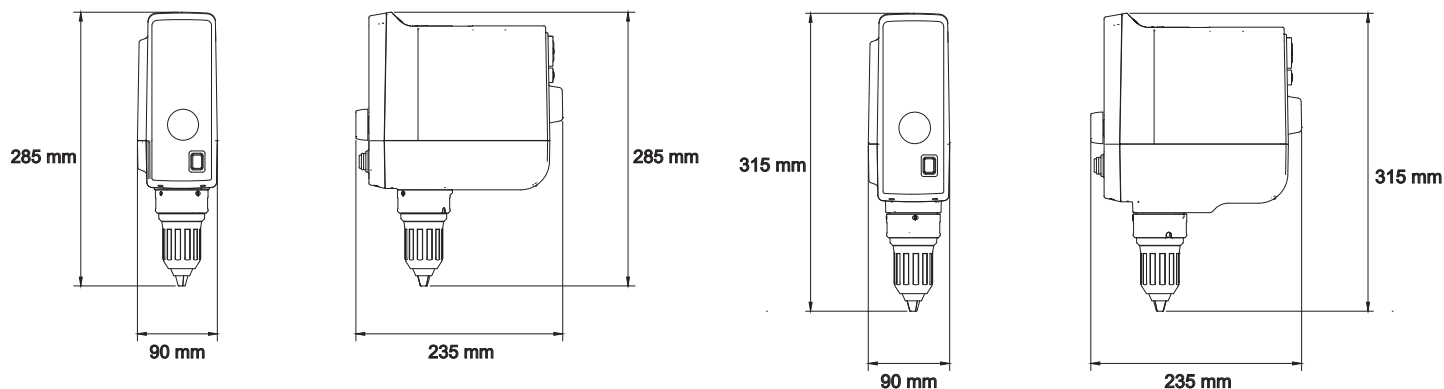

## Other Standard Features & Equipment

Speed accuracy of 1 rpm, sealed housing with IP54 rating, digital display, timer, torque tendency LED indicator, digital speed control, chuck range 1 to 13 mm, pass through shaft diameter up to 8.5 mm, support stand and clamp required for set up (sold separately).

## Compliance

- Product Safety: CAN/CSA C22.2 No. 61010-1, CAN/CSA C22.2 No. 61010-2-051, EN 61010-1, EN 61010-2-051, IEC 61010-1, IEC 61010-2-051, UL 61010-1, UL 61010-2-051
- Electromagnetic Compatibility: EN 61326-1: 2013 Class A Industrial Environment; Canada ICES-003 Class A; FCC Part 15 Class A
- Compliance Marks: CE; RCM; cNus; WEEE; CN RoHS

## Accessories

Support Stand Universal-H .....	30586771
Support Stand Telescopic-H .....	30586772
Clamp Double .....	30586773
Clamp Ribbon .....	30586774
Stirrer Shaft 40x0,7 cm, Anchor Blade .....	30586775
Stirrer Shaft 40x0,7 cm, Fixed Blade .....	30586776
Stirrer Shaft 40x0,7 cm, Floating Blade .....	30586777
Stirrer Shaft 40x0,7cm, Folding Blade .....	30586778
Stirrer Shaft 51x0,7cm, Paddle 6 Holes .....	30586779
Stirrer Shaft 40x0,7cm, Propeller .....	30586780
Stirrer Shaft 40x0,7cm, Turbine .....	30586781
Stirrer Shaft 40x0,7cm, Turbo Propeller .....	30586782
Chuck Cover e-A51 .....	30586842

OHAUS Europe GmbH  
Heuwinkelstrasse 3  
8606 Nänikon  
Switzerland

e-mail: [ssc@ohaus.com](mailto:ssc@ohaus.com)  
Tel: 0041 22 567 53 19  
e-mail: [tsc@ohaus.com](mailto:tsc@ohaus.com)  
Tel: 0041 22 567 53 20

[www.ohaus.com](http://www.ohaus.com)

OHAUS Corporation is an ISO 9001:2008 manufacturer

ISO 9001:2008  
Registered Quality  
Management System

80776606\_D 20200819 © Copyright OHAUS Corporation

