

Instructions for use

Rotor F-45-72-8, Rotor F-45-48-11

English (EN)

This document complements the operating manual for the Concentrator/Vacufuge® and does not replace it. Therefore, please also read the operating manual for the Concentrator before starting up the rotors for the first time. You can find the current version on the Internet at www.eppendorf.com.

1 Using the rotor feet

The rotor feet prevent the vessels from sliding out of the bores when positioning the rotor. The rotor feet may remain in place during centrifugation.

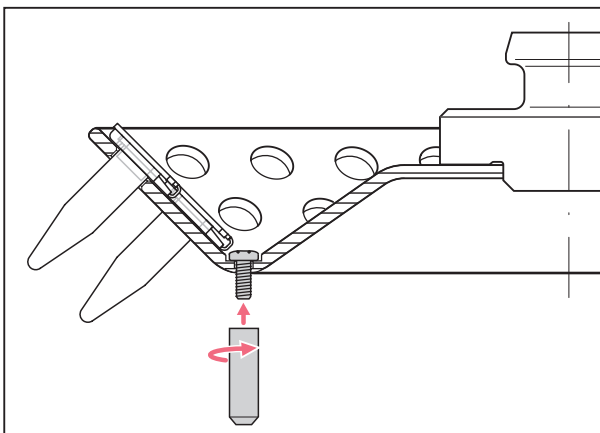

- ▶ Insert the 3 screws through the bores.
- ▶ Tighten the rotor feet.

2 Using the spacer

Use the spacer to centrifuge with 2 rotors at the same time. The rotors can be positioned freely. The following maximum loads apply:

- Lower rotor: $\frac{2}{3}$ of the max. load
- Upper rotor: $\frac{1}{3}$ of the max. load

3 Ordering information

Order no. (International)	Description
5490 034.007	Rotor F-45-72-8 72 positions for 0.5 mL tubes
5490 030.001	Rotor F-45-48-11 48 positions for 1.5/2.0 mL tubes
5301 316.005	Spacer for simultaneous operation of two rotors for F-45-72-8 and F-45-48-11
5490 030.800	Rotor feet for F-45-72-8 and F-45-48-11 Set of 3

Your local distributor: www.eppendorf.com/contact

Eppendorf AG · 22331 Hamburg · Germany

eppendorf@eppendorf.com · www.eppendorf.com